

# Fabricated Rear End Order Form

When ordering your custom housing every dimension, including housing end identification, is critical in building the correct housing for your car or truck. If you have questions, please call our tech guys for assistance. Once completed, please email or fax the form to us along with name and contact number. When your form is received, we will contact you for verification of information and to obtain your billing and shipping information.

## Rear End Housing Order

Type of Housing: Dana 60 \_\_\_\_\_ Ford 9" \_\_\_\_\_

Housing Ends \_\_\_\_\_ Axle Flange to Axle Flange (D) \_\_\_\_\_ Housing Width (E) \_\_\_\_\_

Dr. Side Housing Flg. to Center of Pinion (F) \_\_\_\_\_, Pass. Housing Flg. to Center of Pinion (G) \_\_\_\_\_

Pinion Offset \_\_\_\_\_ • Pinon offset is determined by the difference between (F) and (G) Divided by 2

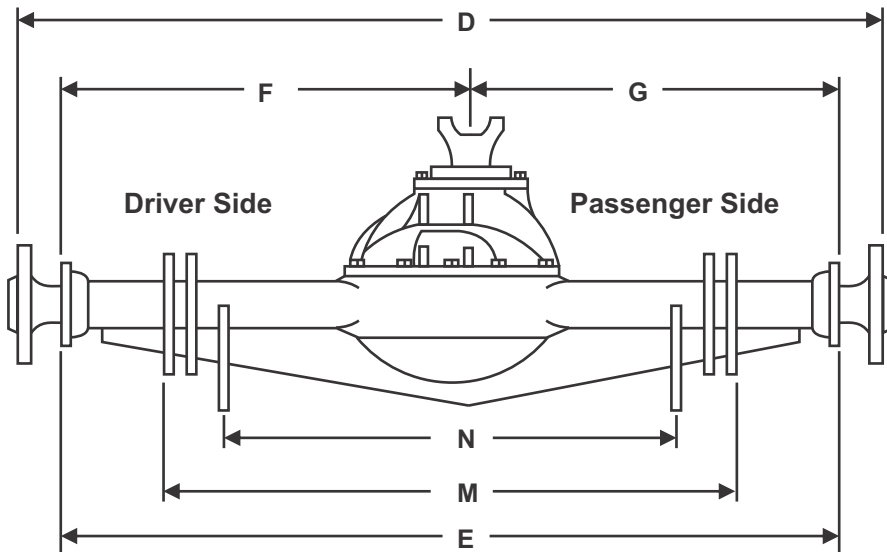

• Ladder Bar Kit -

Pro1 Ladder Bar

OutLaw Ladder Bar

• Four Link Kit

3514

3515

3516

3315

3316

3317

Bracket Welding- Outside to Outside of Suspension Brackets (M) \_\_\_\_\_

Center to Center of Shock Mount Brackets (N) \_\_\_\_\_\*

\*If not using suspension brackets with integrated shock mounts

## Welded Frame Rail Order Form

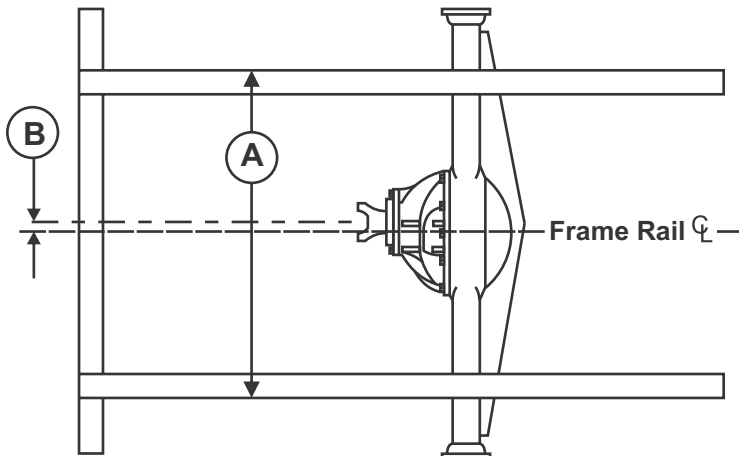

Outside Frame Rail Width (A) \_\_\_\_\_

Pinion Offset (B) \_\_\_\_\_

Suspension Kit:

Four Link: 3625 \_\_\_\_\_ 3626 \_\_\_\_\_

3726 \_\_\_\_\_ 3727 \_\_\_\_\_

Ladder Bar: 3628 \_\_\_\_\_ 3630 \_\_\_\_\_

Upgrades and Additions to Kits: Shocks: Strange Single Adj. \_\_\_\_\_ Double Adj. \_\_\_\_\_ Spring Rate \_\_\_\_\_ lbs.

Anti-Roll Bar 3755 \_\_\_\_\_ Top Gun 3761 \_\_\_\_\_ Top Gun H/D 3762 \_\_\_\_\_

Wishbone \_\_\_\_\_ Heavy Duty Diag. Link \_\_\_\_\_ Top Gun Diag. Link \_\_\_\_\_ Panhard Bar \_\_\_\_\_

Customer Name \_\_\_\_\_ Contact # \_\_\_\_\_

Chassis Engineering: Fax: 561-863-1424 • Email: Info@chassiengineering.com