

Manufacturers and Distributors of quality chassis,
suspension, driveline and components

Tech Line & Information: (561) 863-2188

Orders Only: (800) 327-9402

Fax: (561) 863-1424

C/E 3515/16 - Top Gun 4-Link (with shock mounts)

3515 (Mild Steel) • 3516 (Chrome Moly)

Parts List:

2...Four-link Housing Brackets w/o Shock Mounts	2...Four-link Housing Brackets w/ Shock Mounts
4...Four-link Frame Brackets (Tall)	2...1-1/4" x .095 Wall CM Four-link Tubes
8...5/8" x 3" Bolts	2...1-3/8" x .095 Wall CM Four-link Tubes
8...5/8" Right Hand Jam Nuts	8...5/8" Nylock Nuts
1...36" pc. 1-3/8" x .095 CM Tube	16...5/8" SAE Flat Washers
4...1-1/4" Tube Adapters (2 left, 2 right)	4...1-3/8 Tube Adapters (2 left, 2 right)

NOTES: 3515(mild steel) & 3516 (moly) kits do not include rod ends. Rod ends must be purchased separately. Consult with your salesman for the proper rod ends for your application.

3515/16 Four - link instructions are written with the assumption that suitable frame rails or vertical roll cage bars are already in place.

INSTALLATION:

- 1...Begin by bolting two rod ends tightly between two of the frame mount brackets. One in the top hole and one in the bottom hole. This sets the proper distance between the two brackets.
- 2...Position the bracket assembly on the frame section so that the center line of the bottom hole is 5-7/8 inches off the ground, with the car at ride height. See illustration sheet supplied with instructions. This dimension assumes the use of 32 inch tall tires. If utilizing smaller diameter tires, adjustments downward must be made at this time. Tack weld (Mig or Tig) the brackets into place (3516 brackets must be Tig welded).
- 3...Repeat the procedure for the other side, making sure that both bracket assemblies are level and square to each other and the car.
- 4...Remove the 4 rod ends from the frame mounts.
- 5...The four-link tubes are pre-cut to 18 inches. Cut the tubes to 16-1/4 inches. This allows the tube adapters to be inserted into the tubes and the rod ends installed to the proper predetermined length of 23", center to center. After cutting the tubes to the proper length needed, drill one 5/16" hole, approximately 3/4" from the end of the tube, completely through the tube. At this point your four-link tube should have 2 holes at each end. Insert one left and one right hand tube adapter and plug weld all four holes in the assembly, then weld both ends where the tube adapters and the tube meet. Repeat the procedure for the other 1-3/8" tube and both of the 1-1/4" tubes.
- 6...Set the initial depth of all 8 rod ends to be installed into the tubes. Adjust the jam nuts on the rod ends up to the ball end until there are approximately 5 threads remaining. Install the rod ends into the tubes until the jam nuts contact the tubes. Four-links will utilize 4 left and 4 right hand rod ends.
- 7...Set up one of the tubes so that the center to center measurement of the rod ends is 23 inches and are lined up with each other. Reset the jam nuts to lock the rod ends in place. Insert one bolt in each end. Set the remaining three 4-link tubes up so that they will all line up on the two bolts installed in the first tube. This insures that all four 4-link tubes are the same length. **See Figures 1 and 2.**

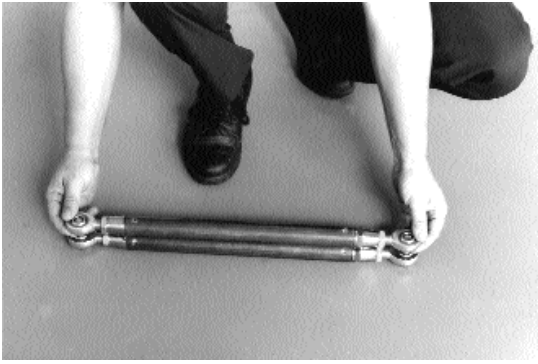

Figure 1

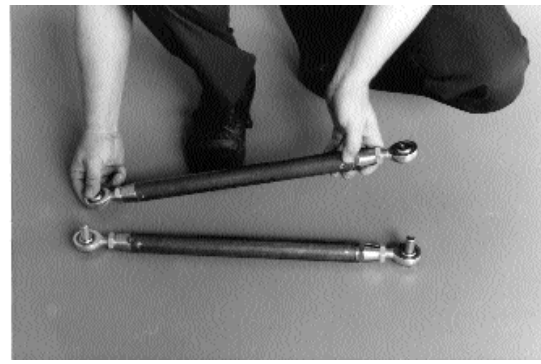

Figure 2

8...Install the 4-link bars, left hand rod ends forward, into the frame brackets in the initial starting locations as indicated on the illustration sheet. The bottom bar in the second hole from the bottom and the top bar in the fourth hole from the top.

9...Slide the 4-link housing brackets onto the rear end housing. The 4-link brackets **with** the shock mounts go on first (inside). The 4-link brackets **without** the shock mounts go on the housing second (outside). Position the housing so that the four 4-link bars can be bolted into the appropriate holes in the housing brackets. Initial hole locations are indicated on the illustration sheet. The bottom bar (1-3/8") should be in the bottom hole and the top bar (1-1/4") should be in the top hole.

10...Position the rear end housing so that the center of the axle tube is 16 inches off the ground, with the car at ride height.

11...Position the brackets on the housing so that the center to center measurement of the housing brackets matches the center to center measurement between the frame mount brackets. This assures that all four 4-link bars are in line with each other.

12...Measure the outside to outside distance of the rear end housing brackets and cut the 1-3/8" tube to length. Slip the tube into each of the housing brackets. This support tube between the four brackets will be welded later.

13...Rotate the rear end in the brackets so the pinion is pointing at the output shaft of transmission.

14...Align the housing right to left in the brackets to center the pinion with the transmission output shaft. Ideally, there would be a center line on the floor left over from the frame rail installation or chassis fabrication. If not, you can construct this line by dropping a plumb bob from the center of the harmonic balancer and marking the spot on the floor. Then repeat the procedure off of the transmission output shaft. Connect these two points with a snap (chalk) line then project the line to the rear of the car.

15...Measure the distance from the center line of the axle tube to the leading edge of the frame mount brackets. This measurement, shown on the illustration sheet, should be very close to 25-1/4 inches. If not, re-check all measurements and go through the procedures to determine the discrepancy. If all measurements are right, tack weld the housing brackets and support tube into place.

16...After tacking everything into place, re-check all measurements again and check for squareness. Once everything has been checked over, remove the rear end housing for final welding.

17...It is recommended that the final welding on the rear end housing be done by a competent shop, on a jig. This will assure that the axle tubes do not warp causing the axles to bind after final assembly. If the rear will not be welded on a jig, then it is recommended that only small sections be welded at a time to prevent excess heat from warping the axle tubes.

18...Weld the frame mount brackets completely with the 4-link bars in place. This assures that the brackets will not move or warp due to the heat of the welding, causing misalignment of the holes.

19...Position the rear end housing under the car and bolt the two lower bars and the driver's side upper bar back into place. Leave the passenger side upper bar free.

20...At this time you should install the track locator of your choice, Diagonal link, Wishbone or Panhard Bar. Follow the appropriate instructions for assembly and installation.

21...At this time replace all of the jam nuts on the 4-link with the nylock nuts supplied and tighten up for final. Make sure to replace the jam nuts on the frame mount brackets also.

22...Adjust the both lower 4-link bars to check and adjust the wheelbase for length and squareness. Use the driver side upper 4-link tube to adjust the pinion angle to 3-4° down compared to the driveshaft. It may be necessary to check the wheelbase again after setting the pinion angle because one will affect the other.

See Figure 3.

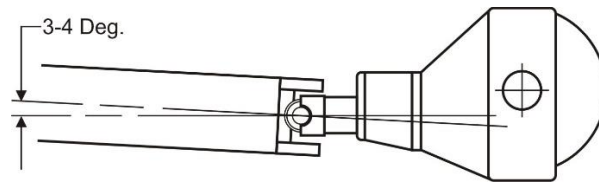
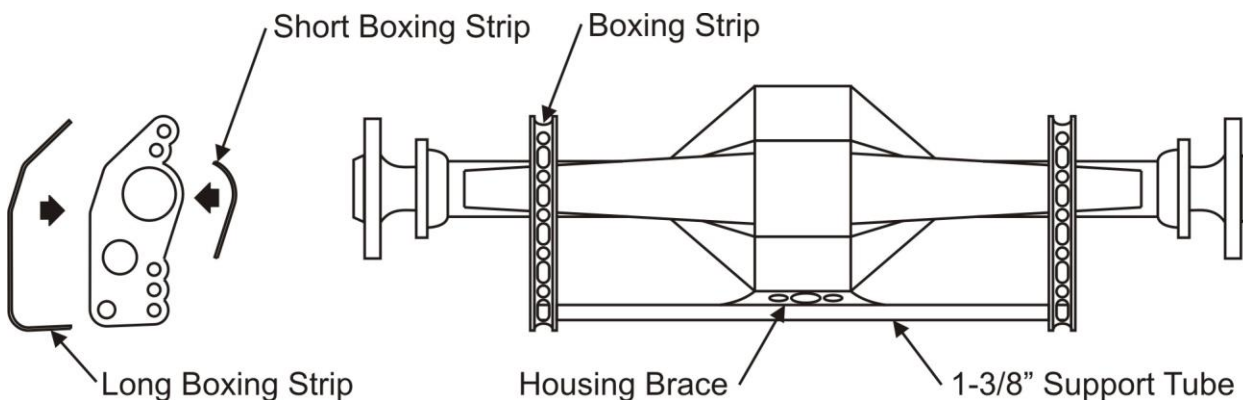

Figure 3

23...Adjust the passenger side upper 4-link tube so that the rear bolt will install without any resistance. For fine suspension adjustments, pre-load, this bar will be used. When adjusting pre-load the passenger side upper bar should only be adjusted 1/4 turn at a time. For further technical assistance contact Chassis Engineering.

24...Replace all jam nuts used for set up with the 3/4" Nylock nuts supplied in the kit and tighten sufficiently.

•• Your kit should have boxing strips for added strength. See diagram below for locations of each. ••



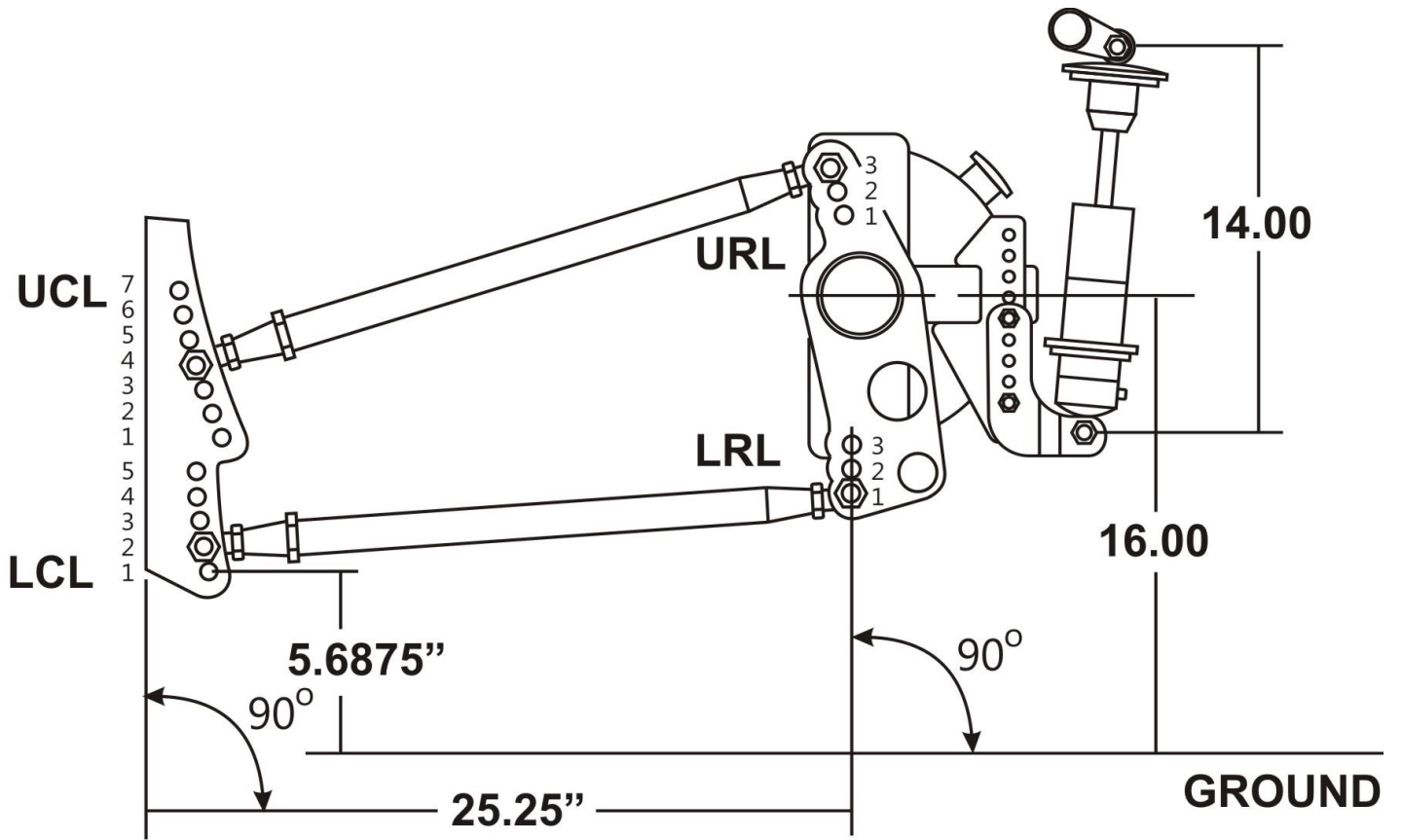

All measurements are shown at ride height, Based on 32" tall tires