



Tech Line & Information: (561) 863-2188

Orders Only: (800) 327-9402

Fax: (561) 863-1424

Manufacturers and Distributors of quality chassis, suspension, driveline and components

9" FORD BACK BRACE SPEC SHEET

Customer Name: _____

Day Time Phone: _____

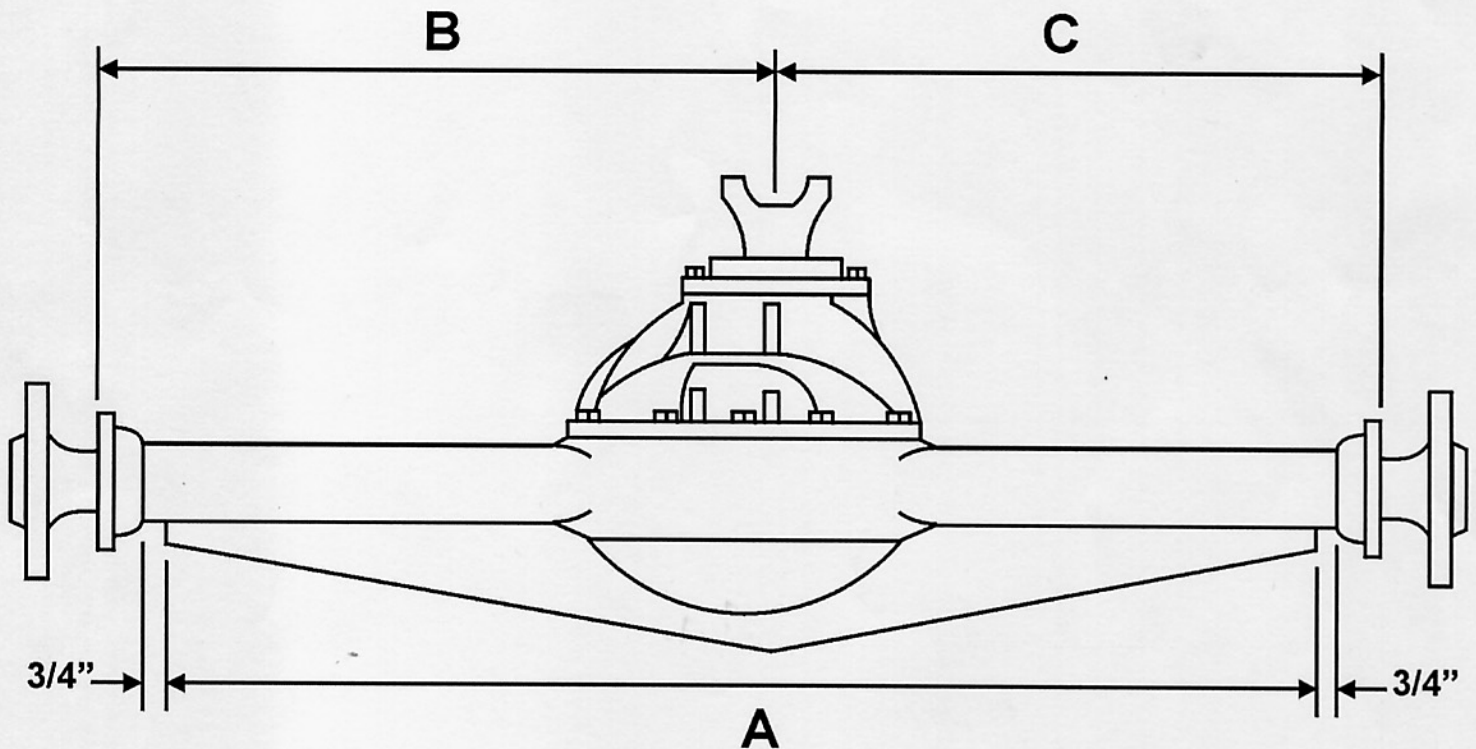

- Small Ford Housing
- Big Ford Housing

A: _____

B: _____

C: _____

Pinion Offset D: _____

A: The actual width that you want the brace to be. Typically it will be 3/4" in from the Housing end

B & C: The distance from the center of the pinion to a line projected forward from the face of the housing end as shown.

D: Pinion Offset is the difference between B and C divided by 2